

2015+ Ford F-150 Fox Suspension Kit

Installation Instructions
P/N: 422014 (R1115-5B450)



2015+ F-150 Fox Suspension

Installation Instructions

P/N: 422014 (R1 1 15-5B450)



Application: 2015+ Ford F-150 4WD

Important Note:

Before installing your ROUSH Performance Product, please read the installation manual and verify that all items are present. If you are missing hardware or have any questions, please contact ROUSH Performance at 1-800-59-ROUSH.

TABLE OF CONTENTS

Packing List For 2015+ F-150 Fox Suspension R1115-5B450.....2
 Equipment and Supplies Required.....2
 Limit of Liability Statement.....2
 Safety Precautions3
 Work Safely!3
 Disassembly4
 Assembly.....7

PACKING LIST FOR 2015+ F-150 FOX SUSPENSION 422014 (R1115-5B450)

Description	Part Number	Quantity
2015+ F-150 Fox Suspension Kit	1115-5B450	1
Website Instructions	1315-P1INST	1
Rear Shock Absorbers	985-24-029	2
Front Coil and Spring Assemblies	985-02-015	2
Shock Cover Kit	803-02-052-KIT	1

EQUIPMENT AND SUPPLIES REQUIRED

- Jack Stands or Hydraulic Lift
- Impact Driver
- 21 mm Socket
- Isopropyl Alcohol
- Floor Jack
- 19 mm Socket
- 18 mm Socket
- Pry Bar
- Ball Joint Puller
- Air Hammer
- Torque Wrench
- 8 mm Socket

If you are missing any items, please call us toll free at 1-800-59-ROUSH.

LIMIT OF LIABILITY STATEMENT

The information contained in this publication was accurate and in effect at the time the publication was approved for printing and is subject to change without notice or liability. ROUSH Performance Products (RPP) reserves the right to revise the information presented herein or to discontinue the production of parts described at any time.

NOTE: 2021 Trucks will require the lower spring perch to be adjusted 5/8" of an inch down on the strut shaft (towards the lower control arm) for proper suspension travel & improved ride.

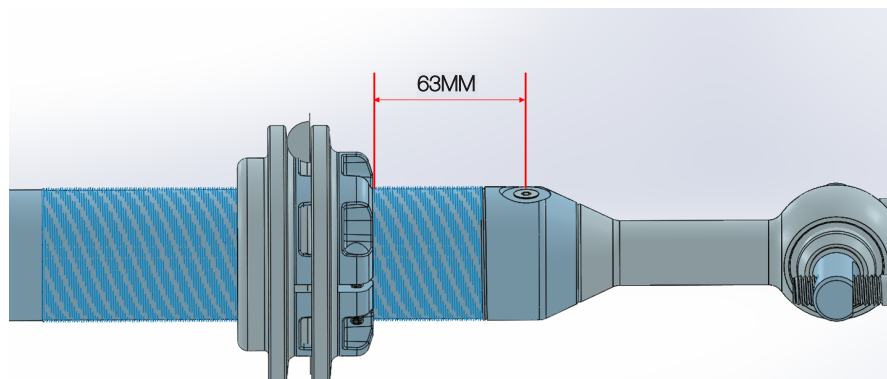

2021 Perch position required. (5/8" LOWER than received)

SAFETY PRECAUTIONS



CAREFULLY READ THE IMPORTANT SAFETY PRECAUTIONS and WARNINGS BEFORE PROCEEDING WITH THE INSTALLATION!

Appropriate disassembly, assembly methods and procedures are essential to ensure the personal safety of the individual performing the kit installation. Improper installation due to the failure to correctly follow these instructions could cause personal injury or death. Read each step of the installation manual carefully before starting the installation.

- Always wear safety glasses for eye protection.
- Place ignition switch in the OFF position.
- Always apply the parking brake when working on a vehicle.
- Block the front and rear tire surface to prevent unexpected vehicle movement.
- If working with a lift, always consult vehicle manual for correct lifting specifications.
- Operate the engine only in well-ventilated areas to avoid exposure to carbon monoxide.
- Do not smoke or use flammable items near or around the fuel system.
- Use chemicals and cleaners in well-ventilated areas.
- Batteries produce explosive gases, which can cause personal injury. Therefore, do not allow flames, sparks or flammable substances to come near the battery.
- Keeps hands and any other objects away from the radiator fan blades.
- Keep yourself and your clothing away from moving parts when the engine is running.
- Do not wear loose clothing or jewelry that can get caught in rotating parts or scratch surface finishes.
- Allow the engine, cooling system, brakes and exhaust to cool before working on a vehicle.

WORK SAFELY!

Perform this installation on a good clean level surface for maximum safety and with the engine turned off.

DISASSEMBLY

The following manual will guide you through the installation of the 2015+ F-150 Fox Suspension Kit (P/N: R1115-5B450).

1. Begin by jacking up the vehicle and removing the wheels as described in the owner's manual.
2. Disconnect the wheel speed sensor electrical connectors. The driver side connector is located on top of the inner wheel liner while the passenger side connector is located on the side of the fuse box.



3. Remove and discard the two (2) anchor plate bolts from each brake caliper assembly. Set the brake caliper assemblies aside and remove each brake rotor.

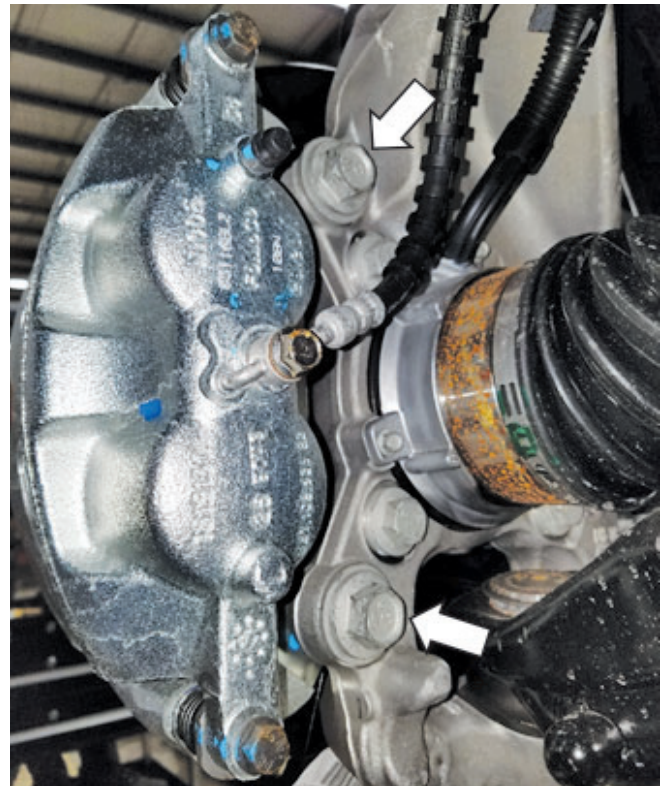

4. Remove the fasteners that retain the front wheel speed sensor brackets and then unclip the front wheel sensor wires from the retainers.



- Remove and discard the wheel hub nut dust cap and the wheel hub nut.

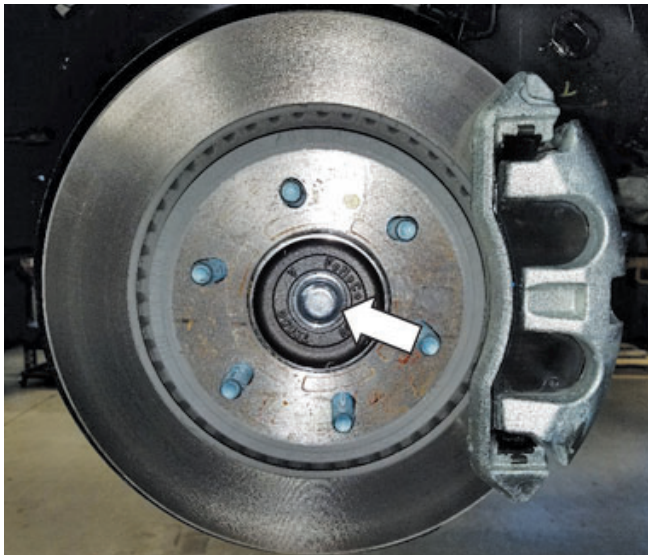

CAUTION

Do not use a hammer to separate the outer tie rod from the spindle or damage may occur. Use the correct Ford separator tool, if necessary.

- Remove and discard the nut from each outer tie rod. If necessary, use the Ford separator tool to remove the tie rod end from the spindle.



- Remove the three (3) fasteners retaining the integrated wheel end (IWE) actuator at the end of each front axle.



- Remove and discard the nut from each upper ball joint. If necessary, use the Ford separator tool to remove the ball joint from the spindle.

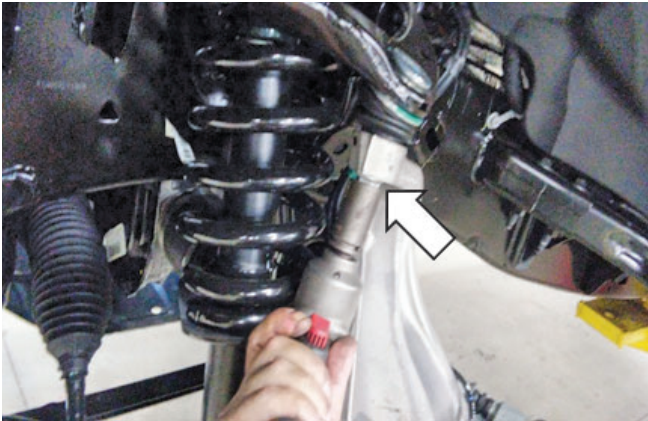

9. Remove and discard the nuts from each lower ball joint using a 19mm socket and remove each spindle. If necessary, use the Ford separator tool.



11. Remove and discard the two (2) lower shock absorber and spring assembly nuts from each lower control arm.



10. Remove and discard the upper nuts from each front stabilizer bar link.

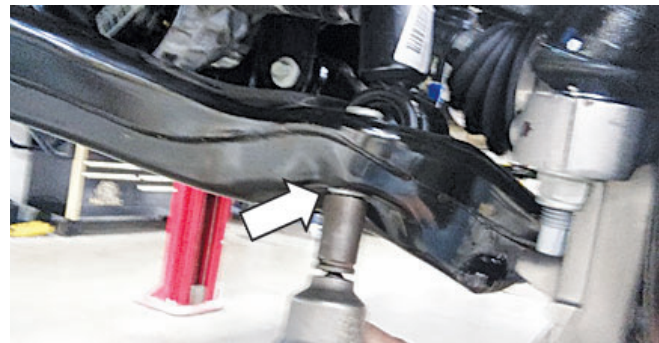

12. Remove and discard the three (3) upper shock absorber and spring assembly nuts from each shock tower. Remove each shock absorber and spring assembly.



13. Place a jack stand under each side of the rear axle to support it while removing the rear shock absorbers.

NOTE: A J-nut is used on the upper LH mount.

14. Remove and discard the upper and lower bolts and nuts for the rear shock absorbers.



ASSEMBLY

2021 VEHICLES! Refer to page 2 for height adjustment prior to installation if not done so already.

Follow the reverse of the disassembly process to reinstall the 2015+ F-150 Fox Suspension Kit while referencing the torque chart shown and utilizing new hardware in the steps that required discarding of the take-off hardware.

Component	Torque Value (Nm)
Front Axle Nuts	40
Front Wheel Speed Sensor Bolts	12
Front Brake Anchor Plate Bolts	250
Lower Ball Joint Nuts	103
Upper Ball Joint Nuts	63
IWE Bolts	12

Component	Torque Value (Nm)
Brake Hose Bracket Bolts	30
Tie Rod End Nuts	103
Shock Absorber and Spring Assembly Upper Nuts*	33
Shock Absorber and Spring Assembly Lower Bolts*	95
Front Stabilizer Link Upper Nut	80
Rear Shock Absorber Upper/Lower Bolts and Nuts	90

* Denotes blue Loctite 242 is required.

NOTE: While reinstalling each front axle into the spindles, hold the constant velocity joint outward to maintain proper spline engagement with the IWE actuator gear.

- Utilizing a hand pump, apply 24 in-Hg of vacuum to the IWE actuator through the large port.
- Measure the distance between the threaded ends of each CV shaft to the inner bearing race. The minimum allowable distance is 15.5 mm. If the distance is less than that, rotate the CV shaft to allow for proper engagement of the IWE and CV splines.

⚠ CAUTION

Installation and torquing of the axle nut without proper engagement will result in damage.

NOTE: Install the new axle nut with vacuum still applied to the IWE.

- Install the rear shock dust covers (P/N: 803-02-052-KIT) as shown below.

