

2015-2026 Roush Mustang V6 & Ecoboost Black-Tip Axle-Back Exhaust

Installation Instructions
P/N: 421837-BLK (1315V6-5231BK)



39555 Schoolcraft Rd, Plymouth MI, 48170 | 800.59.ROUSH

2015-2026 Roush Mustang V6 & Ecoboost Black-Tip Axle- Back Exhaust

Installation Instructions

P/N: 421837-BLK (1315V6-5231BK)



Important Note:

Before installing your ROUSH Exhaust, please read through the installation procedure and verify that all items are present. If you are missing hardware or have any questions, please contact ROUSH Performance at 1-800-59-ROUSH, 9:00 AM to 5:00 PM weekdays.

NOTE: All illustrations in this manual are representative of the 2015-2026 Roush Performance Products Extreme Exhaust System.

TABLE OF CONTENTS

Packing List for Exhaust Kit.....	3
Equipment and Supplies Required.....	3
Limit of Liability Statement.....	4
Safety Precautions	4
Work Safely!	4
Original Exhaust System Removal	5
RPP Exhaust System Installation	6

PACKING LIST FOR V6/I4 EXHAUST KIT 421837-BLK (1315V6-5231BK)

Description	Part Number	Quantity
Muffler Assembly - LH	98-66-BA	1
Muffler Assembly - RH	98-67-BA	1
Exhaust Tip - Black Coated	1318-402592BLK	2
Exhaust Clamp Hardware Kit	1315-V6ORRHWK	1
Clamp - Muffler to Tip	10-0338	2
Clamp - Muffler to Mid-Pipe	94-0052	2
Installation Instructions - One Pager	AM-INST	1

EQUIPMENT AND SUPPLIES REQUIRED

- 3/8" Drive Ratchet
- 3/8" Drive Extension 3"
- 15 mm Socket
- Spray Lubricant (Soapy Water/Glass Cleaner)
- Reciprocating Saw ("Sawzall")
- Marker

If you are missing any items, please call us toll free at 1-800-59-ROUSH.

LIMIT OF LIABILITY STATEMENT

The information contained in this publication was accurate and in effect at the time the publication was approved for printing and is subject to change without notice or liability. ROUSH Performance Products (RPP) reserves the right to revise the information presented herein or to discontinue the production of parts described at any time.

SAFETY PRECAUTIONS



CAREFULLY READ THE IMPORTANT SAFETY PRECAUTIONS and WARNINGS BEFORE PROCEEDING WITH THE INSTALLATION!

Appropriate disassembly, assembly methods and procedures are essential to ensure the personal safety of the individual performing the kit installation. Improper installation due to the failure to correctly follow these instructions could cause personal injury or death. Read each step of the installation manual carefully before starting the installation.

- Always wear safety glasses for eye protection.
- Place ignition switch in the OFF position.
- Always apply the parking brake when working on a vehicle.
- Block the front and rear tire surface to prevent unexpected vehicle movement.
- If working with a lift, always consult vehicle manual for correct lifting specifications.
- Operate the engine only in well-ventilated areas to avoid exposure to carbon monoxide.
- Do not smoke or use flammable items near or around the fuel system.
- Use chemicals and cleaners in well-ventilated areas.
- Batteries produce explosive gases, which can cause personal injury. Therefore, do not allow flames, sparks or flammable substances to come near the battery.
- Keep hands and any other objects away from the radiator fan blades.
- Keep yourself and your clothing away from moving parts when the engine is running.
- Do not wear loose clothing or jewelry that can get caught in rotating parts or scratch surface finishes.
- Allow the engine, cooling system, brakes and exhaust to cool before working on a vehicle.

WORK SAFELY!

Perform this installation on a good clean level surface for maximum safety and with the engine turned off.

ORIGINAL EXHAUST SYSTEM REMOVAL

1. On both sides of the vehicle's dual exhaust system, mark the LH and RH rear side of the exhaust pipes before they curve to the muffler as shown below, at the tangent of the curve.

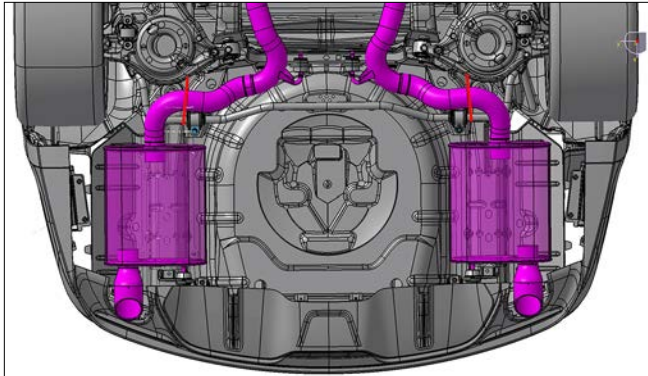

2. Cut the LH and RH exhaust pipes at the locations marked in step 1 using a reciprocating saw with a metal blade. **BE CAREFUL AND DO NOT ACCIDENTALLY CUT ANY OTHER COMPONENTS!**



3. With the exhaust pipe cut, slide the hanger out of the rubber mount and remove the muffler/tip assembly from the vehicle.



NOTE: The disassembly process is identical for the left and right sides of the OEM exhaust. This concludes the disassembly process for the OEM axle-back exhaust.

⚠ WARNING

Use extreme caution during installation. Torque all fasteners according to manufacturer's torque values and tightening sequence. DO NOT use air impact tools to tighten fasteners on ROUSH Performance Products Exhaust Systems. Use of such tools may result in bent flanges or gasket contact areas leading to exhaust leaks which may result in serious personal injury or death.

RPP EXHAUST SYSTEM INSTALLATION

1. Retrieve Roush exhaust components and remove any protective packagings.
2. Slide the provided band clamps (94-0052) over the OE exhaust mid-pipes, one clamp on each side (LH and RH).



3. To install Muffler Assembly - LH (98-66-BA) / (98-67-BA): Insert the Roush muffler hanger into the OE hanger mount at the rear of the vehicle, and then slide the Roush mid-pipe over the OE mid-pipe.

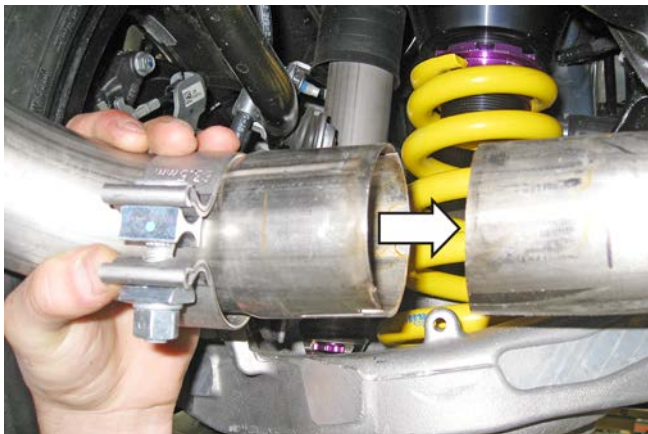

4. Slide the band clamp (94-0052) from step 1 over the mid-pipe joint in step 3 and torque the 15 mm bolt to 30 Nm.



5. Place the band clamp (10-0338) over the exhaust tip and slide the tip over the muffler. Torque the band clamp to 30 Nm once the tip is in position.

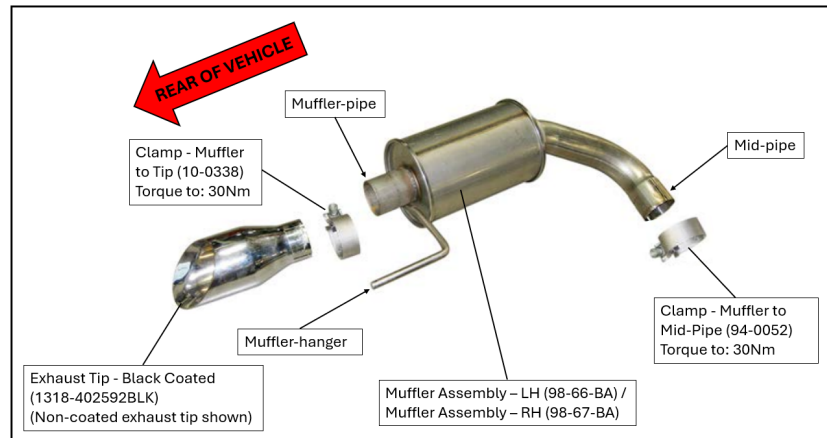

6. Check the exhaust system for correct clearance under the vehicle and also for tip alignment as shown below. If alignment is off, loosen the required band clamp(s), adjust, and re-torque the band clamp(s). (Non-coated exhaust tip shown)



7. Once the desired position and alignment have been achieved, make sure all band clamps are torqued to 30 Nm.



8. Before starting the vehicle, make sure to check all wires, hoses, brake lines, body parts, tires and any other components for safe clearance from the exhaust system.
9. Start the vehicle and check for any leaks. If any leaks are found, determine the cause (such as loose or incorrectly positioned clamp) and repair as necessary. (Non-coated exhaust tip shown)



Congratulations! You have completed the installation process. It is recommended that you save all parts removed from the vehicle during the installation of this kit.