

# 2021-2026 ROUSH F-150 SIDE EXIT CAT BACK PERFORMANCE EXHAUST

## INSTALLATION INSTRUCTIONS

P/N: 421985 (1115-5E2920RR)

422266 (1121-5E2920RR)

422266-BLK (1115-5E292BLK0R)



**ROUSH**<sup>®</sup>  
P E R F O R M A N C E

28200 Plymouth Rd, Livonia, MI 48150 | 800.59.ROUSH

**TABLE OF CONTENTS**

Packing List for 2021-2026 Ford F-150 Off-Road Exhaust Kit .....	3
Equipment and Supplies Required.....	3
Limit of Liability Statement.....	4
Safety Precautions .....	4
Work Safely! .....	4
Section A – Disassembly.....	5
Section B – Assembly .....	5
Cut Lengths per Wheelbase.....	7

**PACKING LIST FOR 2021-2026 FORD F-150 OFF-ROAD EXHAUST KIT**

Description	Part Number	Quantity
Flange and Pipe to Connect to Factory	1115-5G267	1
Front Inlet Pipe	1115-5246	1
Muffler	1115-5230	1
Over-Axle Pipe	1115SE-5C262	1
Y-Pipe for Tips	1115SE-5255	1
Tips	1113SE-5230TIP (422266) OR 1115-5E292BLKOR (422266-BLK)	2
Exhaust Clamp Kit	1115-EXCLMPKIT	1
Tip Clamps	10-0338	2
Pipe Clamps	10-0439	4
Y-Pipe Hanger Bracket	1111-5A204	1
Front Inlet Pipe	PT00042020	1

**EQUIPMENT AND SUPPLIES REQUIRED**

- Metal-Cutting Device (Band Saw, Hack Saw, Cut-off Wheel)
- Ratchet with Extensions
- Metric Socket Sets (deep recommended)
- Torque Wrench

**If you are missing any items, please call us toll free at 1-800-59-ROUSH.**

## LIMIT OF LIABILITY STATEMENT

The information contained in this publication was accurate and in effect at the time the publication was approved for printing and is subject to change without notice or liability. ROUSH Performance Products (RPP) reserves the right to revise the information presented herein or to discontinue the production of parts described at any time.

## SAFETY PRECAUTIONS



### **CAREFULLY READ THE IMPORTANT SAFETY PRECAUTIONS and WARNINGS BEFORE PROCEEDING WITH THE INSTALLATION!**

Appropriate disassembly, assembly methods and procedures are essential to ensure the personal safety of the individual performing the kit installation. Improper installation due to the failure to correctly follow these instructions could cause personal injury or death. Read each step of the installation manual carefully before starting the installation.

- Always wear safety glasses for eye protection.
- Place ignition switch in the OFF position.
- Always apply the parking brake when working on a vehicle.
- Block the front and rear tire surface to prevent unexpected vehicle movement.
- If working with a lift, always consult vehicle manual for correct lifting specifications.
- Operate the engine only in well-ventilated areas to avoid exposure to carbon monoxide.
- Do not smoke or use flammable items near or around the fuel system.
- Use chemicals and cleaners in well-ventilated areas.
- Batteries produce explosive gases, which can cause personal injury. Therefore, do not allow flames, sparks or flammable substances to come near the battery.
- Keeps hands and any other objects away from the radiator fan blades.
- Keep yourself and your clothing away from moving parts when the engine is running.
- Do not wear loose clothing or jewelry that can get caught in rotating parts or scratch surface finishes.
- Allow the engine, cooling system, brakes and exhaust to cool before working on a vehicle.

## **WORK SAFELY!**

Perform this installation on a good clean level surface for maximum safety and with the engine turned off.

## SECTION A – DISASSEMBLY

The following section will guide you through the disassembly and removal of the stock components. Longer wheelbase vehicles will also have an intermediate pipe (not shown) between the factory resonator and the muffler.

1. Remove the two (2) bolts that secure the intermediate pipe and resonator to the catalyst pipe. Set these fasteners aside as they will be re-used.
2. Loosen the clamps that secure the intermediate pipe and resonator to the muffler and tail pipes.
3. Remove the hanger in the center of the vehicle at the rear of the muffler. This will aid in removing and installing the exhaust components.



4. Remove the intermediate pipe and resonator from the vehicle.
5. Slide each of the hangers out of the rubber hangers and remove the factory muffler/tail pipe assembly from the vehicle.

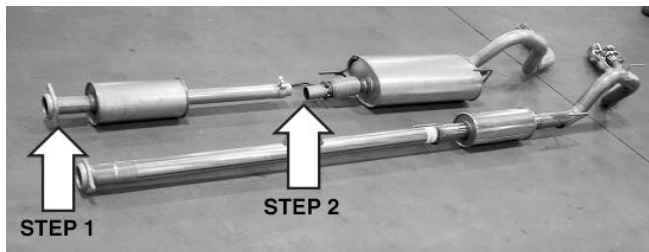

6. 2021 MY ONLY:

Cut front flange off catalyst flange here, SAVE FOR LATER STEP:

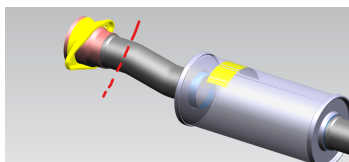

## SECTION B – ASSEMBLY

The following section will guide you through the assembly and installation of the ROUSH components.

1. Loosen the rear spring support bracket bolt so that there is a gap of about 7-10 mm of threads showing.

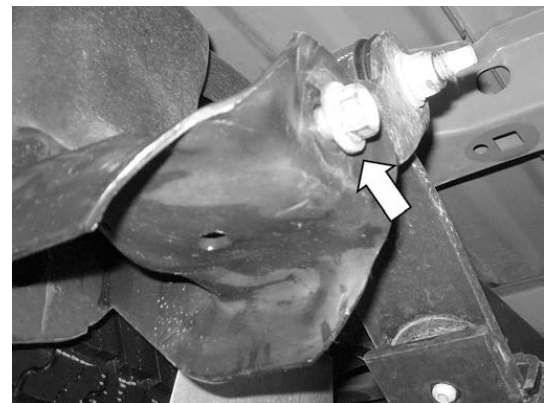
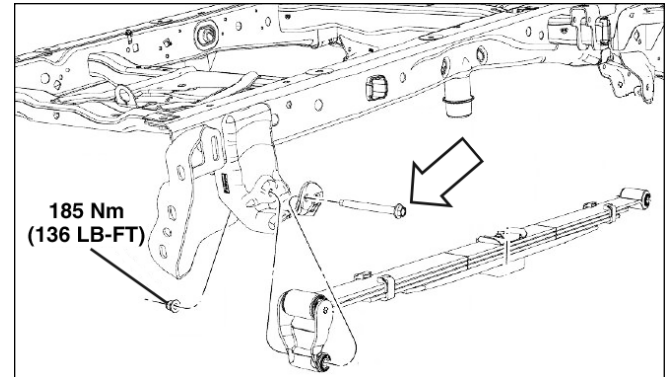

2. 2018-2020 model year: Position the new catalyst pipe adapter flange into place against the catalyst pipe and loosely install the two (2) take-out fasteners to hold it in place.  
2021-2026 model year: Slide over the flange cut off during disassembly in this manual. Position the new catalyst pipe adapter flange into place against the catalyst pipe and loosely install the two (2) take-out fasteners to hold it in place.
3. Position the new muffler outlet axle pipe into position and install the steel hanger brackets into the factory rubber hangers. Orient the pipe such that the flared end faces forward in vehicle. At this time, re-install the hanger bracket that was removed in step 3 of the Disassembly section.
4. Insert one (1) 3" clamp over the outlet end of the new muffler assembly and slide this into the end of the muffler outlet pipe. Position the clamp on the joint and loosely secure.

- There is a list of the cut lengths for this intermediate pipe at the end of this document (P.7-8). Be sure to leave enough length for engagement into the catalyst pipe flange. Mark the pipe and double check BEFORE cutting to ensure it will be cut correctly.

**NOTE:** This intermediate pipe has to be cut to length prior to final installation to fit your particular vehicle wheelbase.

- Remove the intermediate pipe and cut the pipe at the marked length to fit your wheelbase. Make sure to double check your measurement prior to cutting the material. Cut off the end OPPOSITE the hanger that is welded to the pipe. Remove all sharp edges after cutting.
- Re-install the pipe assembly to the catalyst flange. Loosely install the two (2) fasteners.

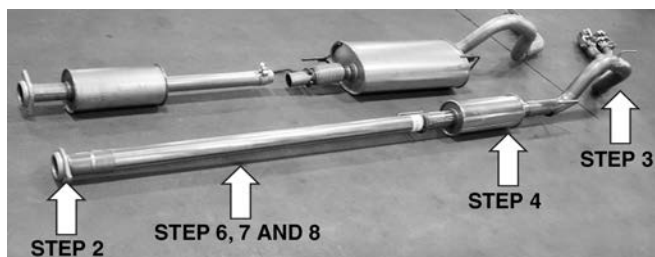

- Install one (1) 2.5" clamp onto each of the exhaust tips and slide the tips onto the ends of the Y-pipe. Position the clamps on the pipe joints and loosely secure the clamps.
- Insert one (1) 3" clamp over the end of the new Y-pipe assembly and slide into position on the end of the muffler outlet pipe.
- Insert the Y-pipe hanger into the hanger bracket. It is important to note the orientation of the bracket as it will hang underneath the suspension bracket.
- Slide the new rear tailpipe support bracket between the head of the bolt and the frame. Re-torque the bolt to 185 Nm. When torquing the leaf spring bolt, this must be done with the vehicle on the ground, not on a hoist. The vehicle must be under its own weight.



- With the full system now hanging in the vehicle, make sure all of the hangers are fully seated and there are no clearance issues with vehicle parts contacting the exhaust system.
- With the system in the desired position, torque all four (4) 3" clamp joints to 50 Nm.
- Torque the two (2) catalyst adapter bolts to 44 Nm.
- Torque the two (2) 2.5" clamps on the tips to 50 Nm.
- On the eco-boost vehicle, there are two (2) hangers at the muffler. The most forward hanger can be removed. Store this with your stock take-off exhaust.

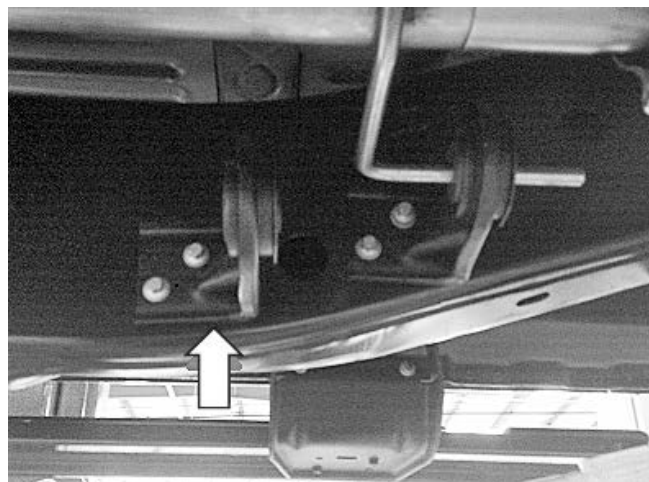

**Congratulations!!!** You have completed the installation of your new ROUSH Performance Products, F-150 Off-Road Exhaust Kit. It is recommended that you save all parts removed from your vehicle during the installation of this kit.

### CUT LENGTHS PER WHEELBASE

122.4 wheelbase (19.6 inches)

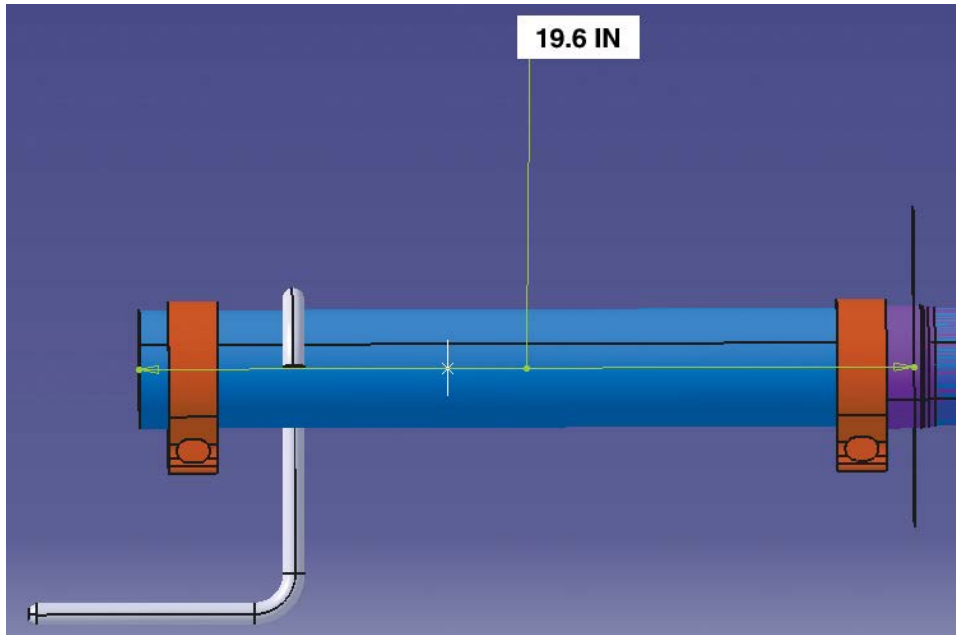

141.1 wheelbase (38.3 inches)

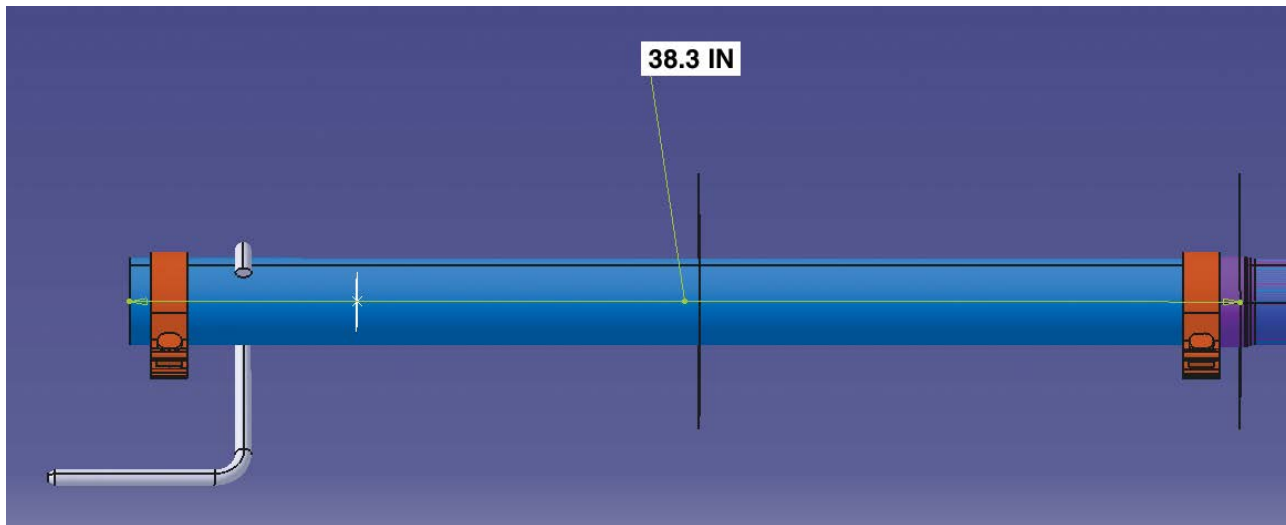

145 wheelbase (42.2 inches)

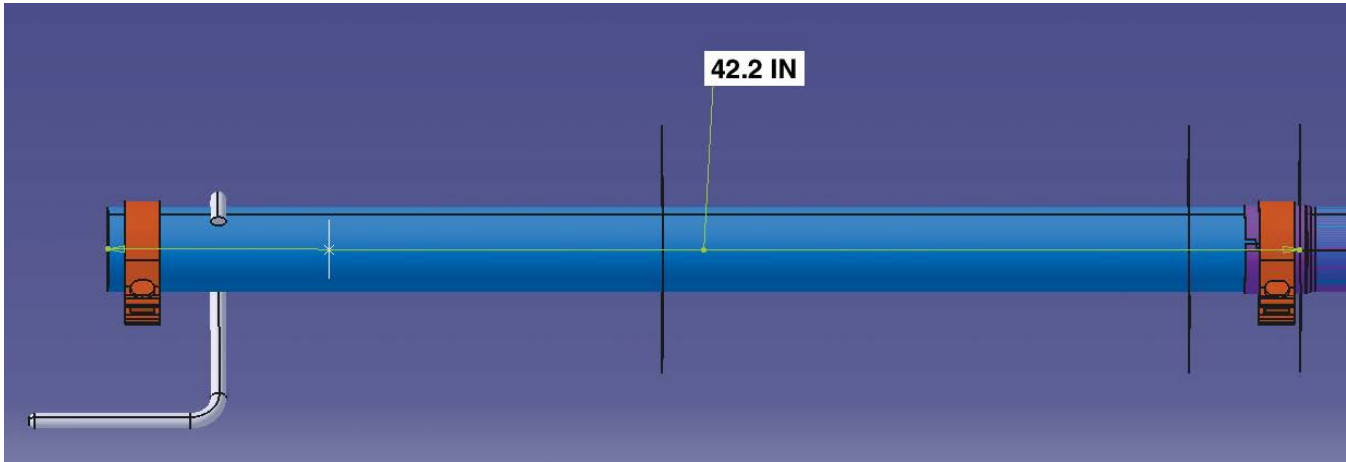

156 wheelbase (54 inches)

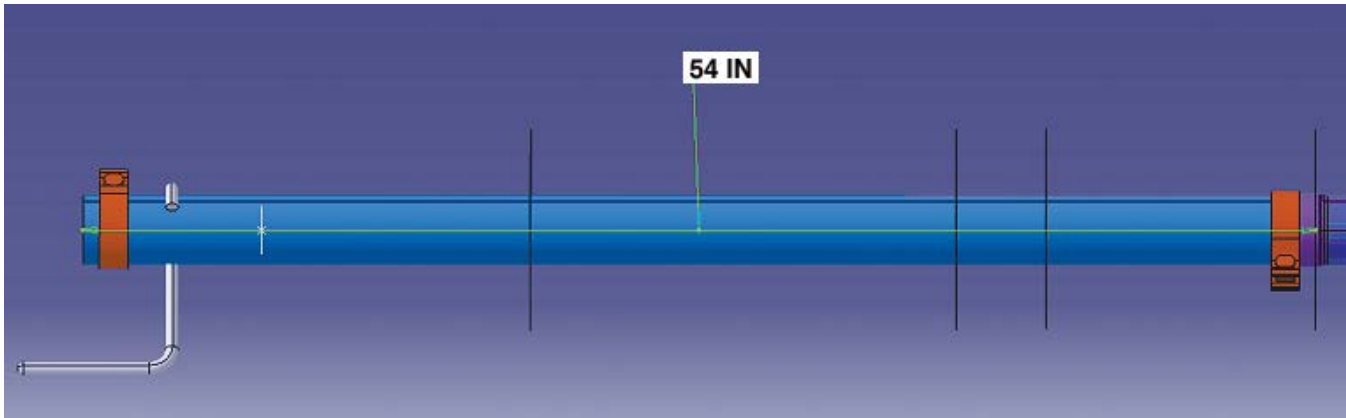

163.7 wheelbase (no cut for this wheelbase)

