

# 2015+ Ford F-150 Phase 2 Upgrade

Installation Instructions  
P/N: 1115-P2UPG

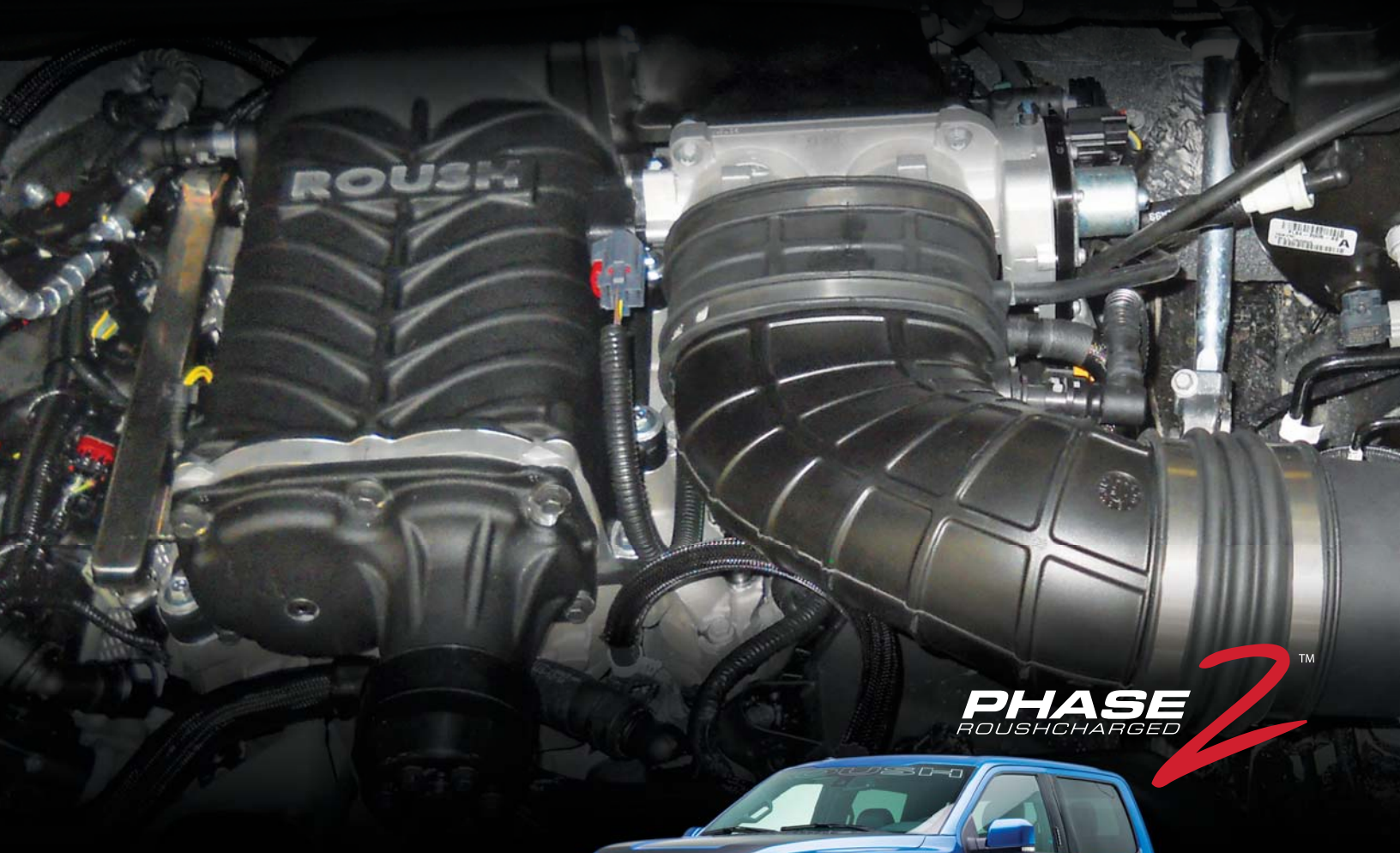

**PHASE**  
ROUSHCHARGED **2**<sup>TM</sup>



# 2015+ F-150 Phase 2 Upgrade

## Installation Instructions

### P/N: 1115-P2UPG

**Application:** 2015-2017 Ford F-150 5.0L

**CARB E.O.:** #D-418-39

**Important Note:**

Before installing your ROUSH Performance Product, please read the installation manual and verify that all items are present. If you are missing hardware or have any questions, please contact ROUSH Performance at 1-800- 59-ROUSH.

**TABLE OF CONTENTS**

Packing List for 2015+ F-150 Phase 2 Upgrade.....	3
Equipment and Supplies Required.....	3
Limit of Liability Statement.....	3
Safety Precautions .....	3
Work Safely! .....	3
Section A – Disassembly.....	4
Section B – Installation.....	4
PCM Flashing.....	5

## PACKING LIST FOR 2015+ F-150 PHASE 2 UPGRADE

Description	Part Number	Quantity
Supercharger Pulley – 75 mm	1311-6K75	1
Voucher Card – P2	P1115-P2-AA	1
EO LABEL	D41839-9A095EO-AA	1

## EQUIPMENT AND SUPPLIES REQUIRED

- 1/4" Drive Torque Wrench
- 1/2" Breaker Bar
- 8 mm Socket

If you are missing any items, please call us toll free at 1-800-59-ROUSH.

## LIMIT OF LIABILITY STATEMENT

The information contained in this publication was accurate and in effect at the time the publication was approved for printing and is subject to change without notice or liability. ROUSH Performance Products (RPP) reserves the right to revise the information presented herein or to discontinue the production of parts described at any time.

## SAFETY PRECAUTIONS



### CAREFULLY READ THE IMPORTANT SAFETY PRECAUTIONS and WARNINGS BEFORE PROCEEDING WITH THE INSTALLATION!

Appropriate disassembly, assembly methods and procedures are essential to ensure the personal safety of the individual performing the kit installation. Improper installation due to the failure to correctly follow these instructions could cause personal injury or death. Read each step of the installation manual carefully before starting the installation.

- Always wear safety glasses for eye protection.
- Place ignition switch in the OFF position.
- Always apply the parking brake when working on a vehicle.
- Block the front and rear tire surface to prevent unexpected vehicle movement.
- If working with a lift, always consult vehicle manual for correct lifting specifications.
- Operate the engine only in well-ventilated areas to avoid exposure to carbon monoxide.
- Do not smoke or use flammable items near or around the fuel system.
- Use chemicals and cleaners in well-ventilated areas.
- Batteries produce explosive gases, which can cause personal injury. Therefore, do not allow flames, sparks or flammable substances to come near the battery.
- Keep hands and any other objects away from the radiator fan blades.
- Keep yourself and your clothing away from moving parts when the engine is running.
- Do not wear loose clothing or jewelry that can get caught in rotating parts or scratch surface finishes.
- Allow the engine, cooling system, brakes and exhaust to cool before working on a vehicle.

## WORK SAFELY!

Perform this installation on a good clean level surface for maximum safety with the engine turned off.



### SECTION A – DISASSEMBLY

The following section will guide you through the preparation for the installation of your ROUSH F-150 Phase 2 Upgrade Kit.

1. Loosen the M6 bolts from the supercharger hub.



2. Remove the belt from the supercharger by rotating the tensioner counterclockwise and removing the FEAD belt from the supercharger pulley. Then remove the supercharger pulley.

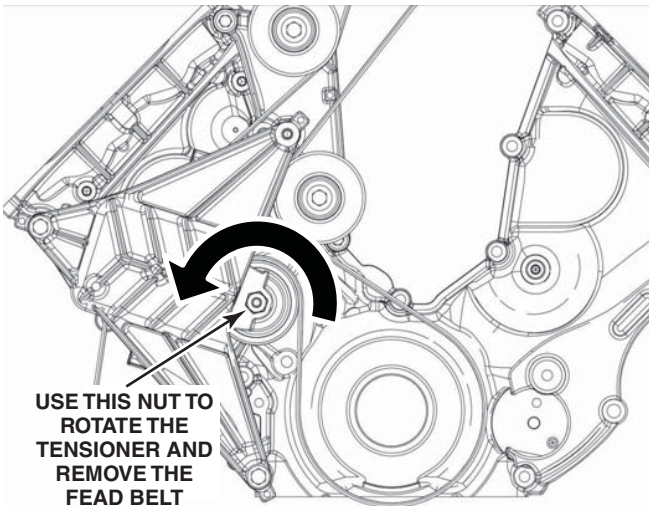

### SECTION B – INSTALLATION

1. Install the new 75 mm supercharger pulley onto the hub of the supercharger using the six (6) M6 x 16 bolts. Apply a small amount of thread locking compound to each bolt and torque to 8-12 Nm. **NOTE:** You will need to torque the supercharger pulley bolts once the FEAD belt is installed.

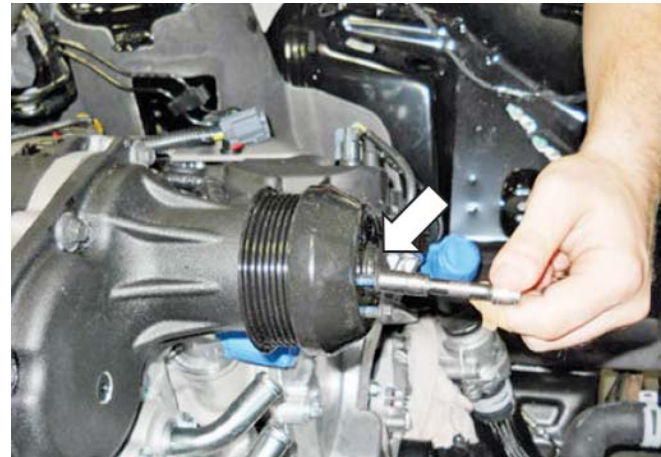

2. Re-install the FEAD belt on the supercharger by rotating the tensioner clockwise and routing the belt as shown in the routing below.

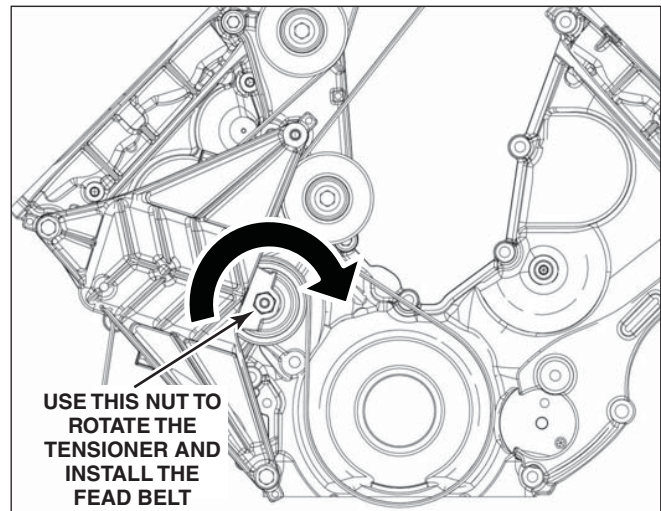

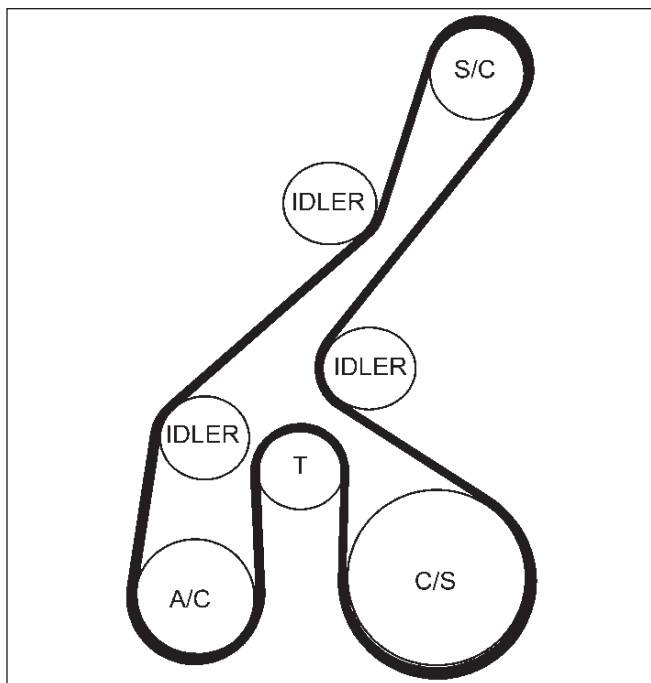
**EO Label:**

1. Place EO Label in Engine bay near Belt Routing Deal

**PCM Flashing**

1. If equipped with a SAE J2534 pass through device, refer to the RDT-CALIM manual found on our website. The RDT-CALIM manual will guide you through the ROUSH Diagnostic Tool (RDT) software installation process and the ROUSH PCM flashing procedure. **OPERATING THE ENGINE WITHOUT THE RECALIBRATED PCM WILL RESULT IN ENGINE DAMAGE OR FAILURE AND WILL VOID THE WARRANTY.**
2. Once the PCM has been successfully recalibrated, start the engine and check for unusual noises, dash service lights, and unusual operation. If problems are detected, immediately stop the engine or vehicle, diagnose and repair the problem.

If you do not have a SAE J2534 device, you can send your PCM to Roush Performance along with the voucher card. Upon receipt, a customer service representative will contact you to arrange payment.

ATTN: PCM FLASH  
39555 Schoolcraft Rd.  
Plymouth, MI 48170