

2015-2026 ROUSH MUSTANG FRONT & REAR ADJUSTABLE SWAY BARS

INSTALLATION INSTRUCTIONS

P/N: 422340

1324-SBK



ROUSH[®]
P E R F O R M A N C E

28200 Plymouth Rd, Livonia, MI 48150 | 800.59.ROUSH

2015-2026 Roush Mustang Front & Rear Adjustable Sway Bars

P/N: 422340

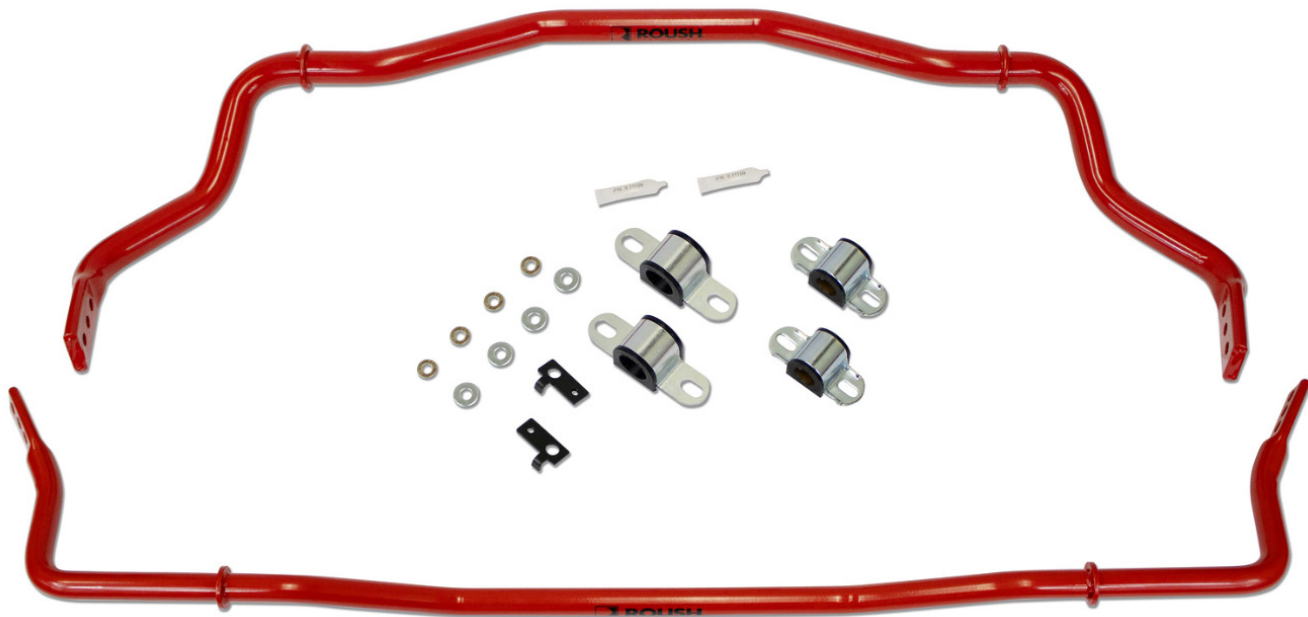

Application: 2015-2026 Ford Mustang 5.0

Important Notes:

- Before installing your ROUSH Performance Product, please read the installation manual and verify that all items are present. If you are missing hardware or have any questions, please contact ROUSH Performance at 1-800-59-ROUSH.

Table of Contents

Packing List.....	3
Equipment and Supplies Required	3
Limit of Liability Statement	4
Safety Precautions.....	4
Front Sway Bar - Removal and Install	5
Rear Sway Bar - Removal and Install.....	6

PACKING LIST

Description	Part Number	Quantity
Sway Bar KIT - ROUSH BRANDED - RED	1324-SBK	1
Front Sway Bar	50335-993-3001	1
Hardware Kit - FRT SWAY BAR	50335-777	1
Rear Sway Bar	51335-993-3001	1
Hardware Kit - RR SWAY BAR	51335-777	1
RETAIL DOCUMENT KIT	RETAILDOC	1

EQUIPMENT AND SUPPLIES REQUIRED

- Floor Jack and Jack Stands or Hydraulic Lift
- Impact Wrench
- Torque Wrench
- Socket Extension
- 21 mm socket
- 18 mm deep socket
- 18 mm socket
- 17 mm wrench
- 13 mm socket
- 7 mm socket

If you are missing any items, please call us toll free at 1-800-59-ROUSH.

LIMIT OF LIABILITY STATEMENT

The information contained in this publication was accurate and in effect at the time the publication was approved for printing and is subject to change without notice or liability. ROUSH Performance Products (RPP) reserves the right to revise the information presented herein or to discontinue the production of parts described at any time.

SAFETY PRECAUTIONS



CAREFULLY READ THE IMPORTANT SAFETY PRECAUTIONS and WARNINGS BEFORE PROCEEDING WITH THE INSTALLATION!

Appropriate disassembly, assembly methods and procedures are essential to ensure the personal safety of the individual performing the kit installation. Improper installation due to the failure to correctly follow these instructions could cause personal injury or death. Read each step of the installation manual carefully before starting the installation.

- Always wear safety glasses for eye protection.
- Place ignition switch in the OFF position.
- Always apply the parking brake when working on a vehicle.
- Block the front and rear tire surface to prevent unexpected vehicle movement.
- If working with a lift, always consult vehicle manual for correct lifting specifications.
- Operate the engine only in well-ventilated areas to avoid exposure to carbon monoxide.
- Do not smoke or use flammable items near or around the fuel system.
- Use chemicals and cleaners in well-ventilated areas.
- Batteries produce explosive gases, which can cause personal injury. Therefore, do not allow flames, sparks or flammable substances to come near the battery.
- Keep hands and any other objects away from the radiator fan blades.
- Keep yourself and your clothing away from moving parts when the engine is running.
- Do not wear loose clothing or jewelry that can get caught in rotating parts or scratch surface finishes.
- Allow the engine, cooling system, brakes and exhaust to cool before working on a vehicle.
- Do not use power tools to remove or install the stabilizer bar link nuts. Damage to the stabilizer bar link ball joints and boots may occur.

WORK SAFELY!

Perform this installation on a good clean level surface for maximum safety and with the engine turned off.

Front Sway Bar - Removal and Installation

1. Begin by jacking up the vehicle using a Floor Jack and Jack Stands or Hydraulic Lift. Remove the front wheels using a 21 mm deep socket and an impact wrench, save take-off parts for re-install.

TORQUE: 150 lb.ft (204 Nm)

2. Remove the front stabilizer bar link lower nuts located in the front driver AND passenger wheel wells using a 18 mm deep socket with an impact wrench, and a 17 mm wrench, save take-off parts for re-install. Position aside the front stabilizer bar link. NOTE: If needed, purchase new OEM nuts for installation. TORQUE: 85 lb.ft (115 Nm)

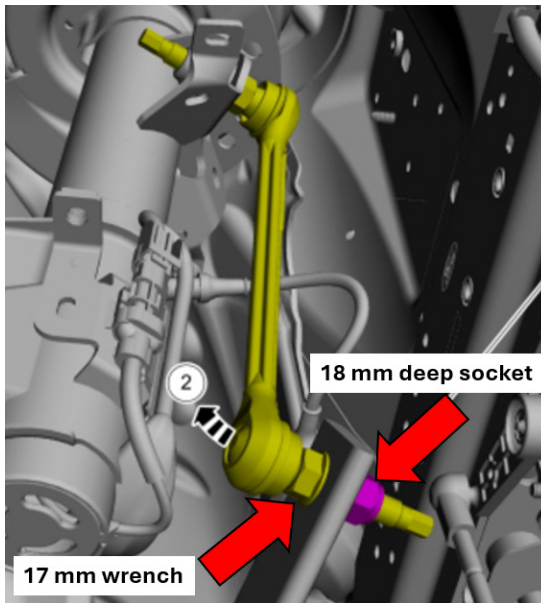

3. Remove the push pins, the bolts and the underbody shield using a 7 mm socket wrench and a clip removal tool. Save take-off parts for re-install. NOTE: When installing, follow the sequences below. TORQUE: 18 lb.in (2 Nm)

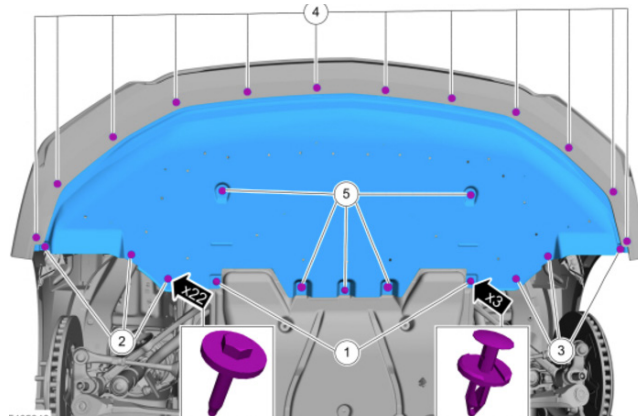

4. Remove the retainers, the bolts and the engine front under-shield using a 7 mm socket wrench and a clip removal tool. Save take-off parts for re-install. NOTE: When installing, follow the sequences below. TORQUE: 18 lb.in (2 Nm)

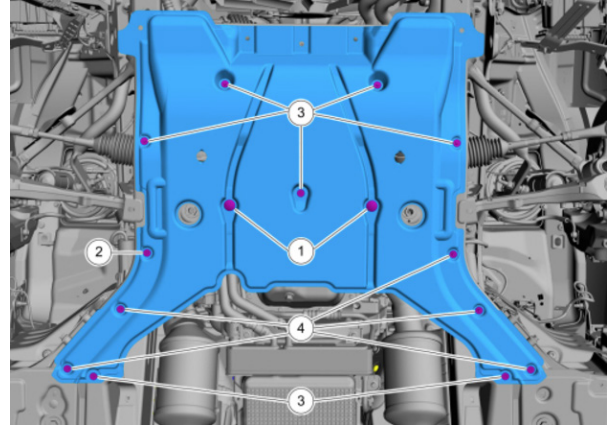

5. If equipped: Position the splash shield up out of the way to gain access to the rearward front stabilizer bar bushing bracket bolt. NOTE: Shield located on LH side of vehicle.

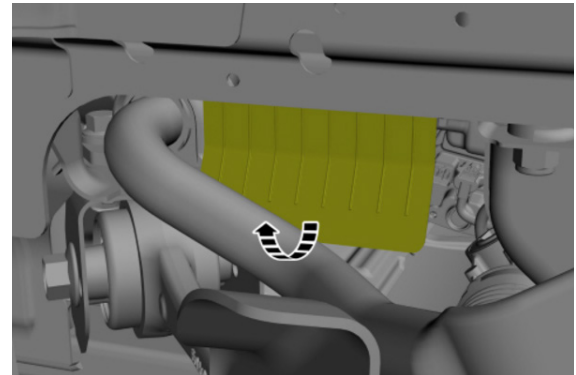

6. Remove the front stabilizer bar bushing bracket bolts on BOTH sides of the vehicle using a 18 mm socket with an extension and an impact wrench. NOTE: If needed, remove the vehicle airboxes to gain more access to the bracket bolts from the enginebay. Save take-off parts for re-install. If needed, purchase new OEM bolts for installation. TORQUE: 81 lb.ft (110 Nm)

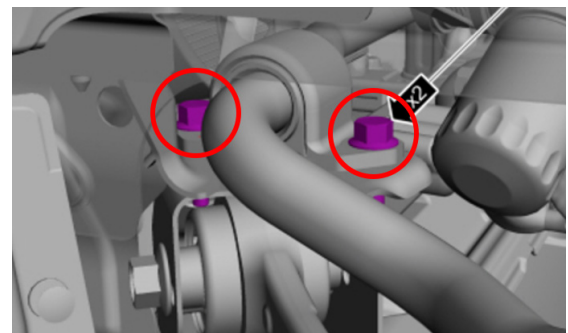

7. Remove the OEM stabilizer bar, discard part. NOTE: If needed, move the brake disc to gain more access.

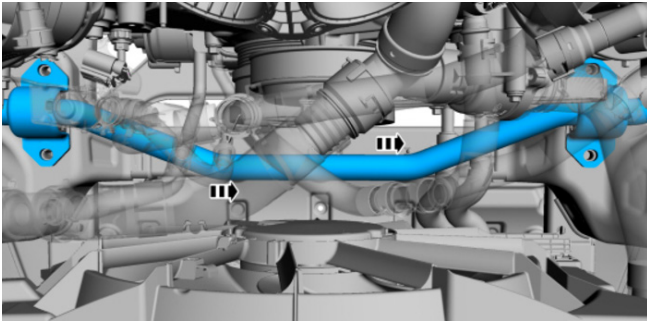

8. Installation is the opposite of Removal. When installing, use take-off OEM bracket bolts & nuts, Front Sway Bar (PN: 50335-993-3001), AND Hardware Kit - FRT SWAY BAR (PN: 50335-777). Make sure to tighten ALL hardware before torquing.

*IMPORTANT NOTE: To install the front stabilizer bar link onto the Roush front sway bar (Opposite of Step 2) There are three (3) settings:

- Inner holes: stiffest (track) setting.
- Middle holes: medium (sport) setting.
- Outer holes: normal (street) setting.

Front and rear sway bar settings does not have to match. (Ex. Front sway bar in track setting, rear sway bar in street setting)

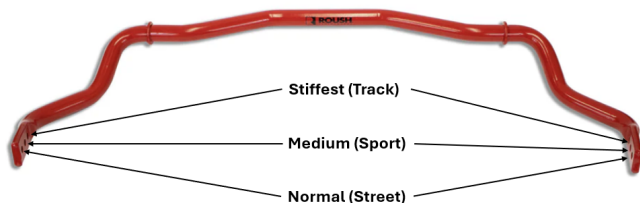

Rear Sway Bar - Removal and Installation

1. Begin by jacking up the vehicle using a Floor Jack and Jack Stands or Hydraulic Lift. Remove the rear wheels using a 21 mm deep socket and an impact wrench, save take-off parts for re-install.

TORQUE: 150 lb.ft (204 Nm)

2. Remove the stabilizer bar link upper nut and position the stabilizer bar link aside located in the rear driver AND passenger wheel wells using a 18 mm socket and an impact wrench, save take-off parts for re-install. TORQUE: 85 lb.ft (115 Nm)

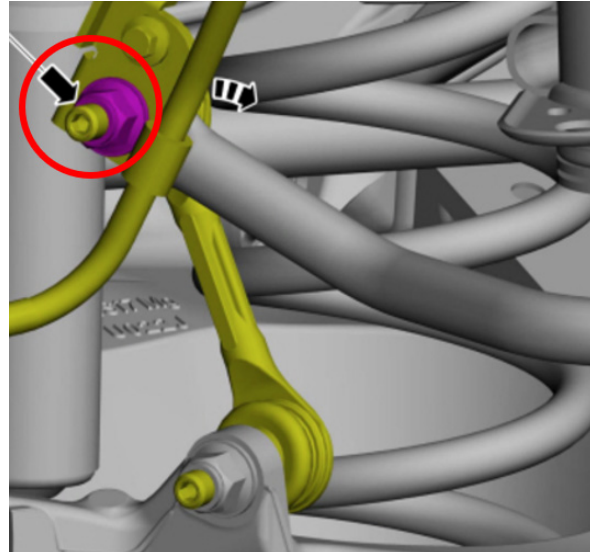

3. Remove the stabilizer bar bracket bolts on BOTH sides of the vehicle using a 13 mm socket with an extension and an impact wrench, then remove the stabilizer bar brackets and remove the stabilizer bar. Save take-off parts for re-install. TORQUE: 52 lb.ft (70 Nm)

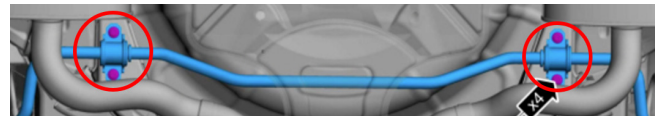

4. Installation is the opposite of Removal. When installing, use take-off OEM bracket bolts & nuts, Rear Sway Bar (PN: 51335-993-3001), AND Hardware Kit - RR SWAY BAR (PN: 51335-777). Make sure to tighten ALL hardware before torquing.

*IMPORTANT NOTE: To install the rear stabilizer bar link onto the Roush rear sway bar (Opposite of Step 2) There are three (3) settings:

- Inner holes: stiffest (track) setting.
- Middle holes: medium (sport) setting.
- Outer holes: normal (street) setting.

Front and rear sway bar settings does not have to match. (Ex. Front sway bar in track setting, rear sway bar in street setting)



Congratulations! You have completed the installation process.

To register your Roush product, go to: <https://support.roushperformance.com/s/article/ROUSH-Performance-Warranty-Information>

